

Bx1x00 Control board for electromechanical gearmotors

**ULIXES 24V
ALPHEO 24V
ZEFIRO 24V
HERMES**

CE



ATTENTION !

- The present user manual is designed for personnel skilled in installation, not for the final user; the electrician is then due to inform the user about modes of use of the device, possible danger and about the necessity to apply periodical maintenance.
- The installation can be carried out only by skilled personnel and in compliance with the rules currently in force regarding the automated locks. In particular, the installation requires the following of the regulations 89/392 and norm EN 12453 and EN 12445..
- Use only original parts. Stagnoli do not take any responsibility for damage caused by using unoriginal parts.
- Before operating the device, make sure that the power supply has been cut off.
- The feeding cable can be connected only with feeders supplied with proper electric protection. In particular, make sure that the distance between the contacts is of at least 3.5 mm in order to avoid omnipolar disconnection from the grid.
- Take into consideration the safety devices to be installed and the place where they should be positioned. Always have an emergency stop device available to allow proper detachment of the feeding cable.
- Do not operate the machine with wet or damp hands or feet and avoid exposing the machine to atmospheric conditions.
- The device should be used only according to the purpose that it has been designed for, any other use is to be considered as improper and therefore dangerous.
- Maintenance, including possible replacement of courtesy light unit , can be carried out only by skilled staff.
- Safety units should be checked periodically.

TECHNICAL SPECIFICATION AND CONNECTION DIAGRAM

The Bx1x00 electronic control unit for 24V electromechanical gear motors of Stagnoli, is designed for controlling operations of 24 Vdc motors, used for the activation of gates with 1 or 2 leafs (i.e. ULIXES 24V, ALPHEO 24V, ZEFIRO 24V, HERMES); the movement is controlled by the encoder and there is no need to use limit switches.

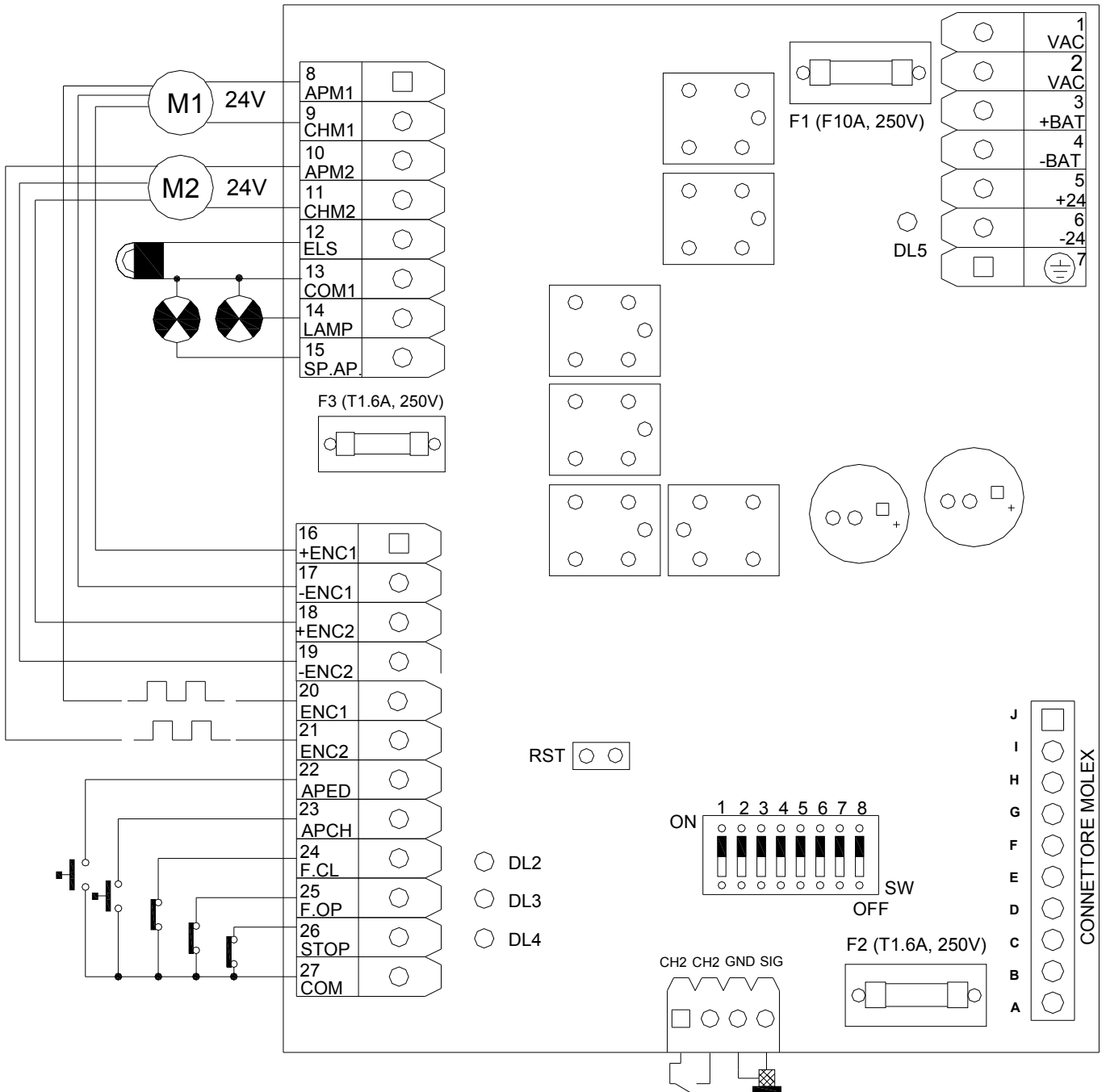

ELECTRIC CONNECTIONS

1. Neutral power supply from transformer (20Vac)
2. Phase power supply from transformer (20Vac)
3. Battery connection (positive pole).
4. Battery connection (negative pole).
5. Auxiliary output 24Vdc – 500mA (positive pole)
6. Auxiliary output 24Vdc – 500 mA (negative pole)
7. Connection of grounding

8. Output 1° electric motor 24Vdc (opening)
9. Output 1° electric motor 24Vdc (closing)
10. Output 2° electric motor 24Vdc (opening)
11. Output 2° electric motor 24Vdc (closing)
12. Output of electromagnetic lock
13. Common.
14. Blinking logic output (24V – 20W max.)
15. Output dial lamp – gate open (24V – 20W max.)

16. Power supply Encoder positioned on 1° motor (+) **(for Hermes and Zefiro 350 24 V)**
17. Power supply Encoder positioned on 1° motor (-) **(for Hermes and Zefiro 350 24 V)**
18. Power supply Encoder positioned on 2° motor (+) **(for Hermes and Zefiro 350 24 V)**
19. Power supply Encoder positioned on 2° motor (-) **(for Hermes and Zefiro 350 24 V)**
20. Signal input Encoder positioned on 1° motor.
21. Signal input Encoder positioned on 2° motor.
22. Electric contact normally opened by Pedestrian Command
23. Electric contact normally opened by Open/Close Command.
24. Electric contact normally closed by the photocell for the closing operation.
25. Electric contact normally closed by the photocell for the opening operation.
26. Electric contact normally closed by the Stop button.
27. Common.
28. 2nd output – radio channel (unpolarized contact)
29. 2nd output – radio channel (unpolarized contact)
30. Input antenna (braided wire).
31. Input antenna (signal).

Connections radio card (CONNECTOR MOLEX)

- A. Input antenna (signal).
- B. Input antenna (braided wire)
- C. Power supply receiver: 24V dc (negative pole)
- D. Power supply receiver: 24V (positive pole)
- E. Disconnected
- F. Disconnected
- G. 2nd input receiver channel
- H. 2nd input receiver channel
- I. 1st input receiver channel (parallel to input of Open/Close)
- J. 1st input receiver channel (parallel to input of Open/Close)



- **IT IS COMPULSORY POSITIONING THE EARTH WIRE CONNECTION (TERMINAL 7)**
- **N.C Contacts that are not used should be short circuited.**
- **N.O Contacts that are not used, should be left.**
- **Double insulated cables should be used when connected to low voltage devices.**
- **In order to follow the regulations of “ Low Safety Voltage” rule (EN 60335-1), the single insulated cables used for 230V supply should be equipped with additional insulation of at least 1 mm, and should be at least 4 mm from those with low voltage.**
- **The cables used for power supply of motors, should be of at least 2.5 mm² and the length should not exceed 12 m;**

DEFINITIONS OF CONTROL UNIT PARTS

F1- FUSE TRANSFORMER INPUT(F10A, 250V):

protects the center in case of short circuits or faults that may emerge at the transformer input.

F2 – FUSE AUXILIARY OUTPUT (T1.6A, 250V): protects the center in case of short circuits and faults that may emerge in auxiliary devices.

F3 – FUSE BLINKER (T1.6 A, 250V): protects in case of short circuits and faults that may emerge in the blinker or in the control device of the opened gate.

DIP SWITCH FOR SELECTION OF FUNCTION MODES:

SW – 1 indicates torque of 1st motor (electric friction M1).

SW – 2 indicates torque of 2nd motor (electric friction M2).

SW – 3 indicates the operational sequence of the command Open/Close.

SW – 4 allows the set up of the function mode for automatic o semiautomatic.

SW – 5 allows the insertion “ battering ram” during the opening phase.

SW – 6 allows selection of delaying the second in respect to the first shutter.

SW – 7 allows selection of operating with 1 or 2 motors.

SW – 8 allows adjustment of the mains for automatic cycle and intervals.

LED – SIGNALLING:

DL2 – (RED): a Led which signals activation of the photocell in the closed mode; the LED automatically switches off when the photocell detects an obstruction during closing.

DL3 – (RED): a Led which signals activation of the photocell in the opened mode; the LED automatically switches off when the photocell detects an obstruction.

DL4 – (RED): a Led which signals blockade of the gate; the LED automatically switches off when the command Stop is activated.

DL5 – (RED): a Led which signals whether the central unit is plugged(on) or not(off); in the case of supply from the accumulator the LED switches off.

INPUTS/OUTPUTS DEFINITIONS

- **Input power supply from transformer** : 20V~ +/- 10%.
- **Input/ output accumulators** : 2 batteries in series from 12V – 3Ah
- **Auxiliary output** (24V $\overline{=}$, 500 mA max): used only for feeding safety devices and accessories.
- **Motors outputs** (24V $\overline{=}$,120W): the motor connected to the terminals 8 - 9 (M1) starts first in the phase of opening; the motor connected to the terminals 10 -11 (M2) starts first in the phase of closing.
- **Electromagnetic lock output** : allows activation of the lock 1 second before the start of M1 motor.
- **Blinker output** (24V, 25W max): the unit allows to signal movement of the gate(blinking), the interval during the automatic operation (steady light for 3 seconds) and possible activation of the safety device during the same interval (blinking maximum 10 seconds); it signals also the subsequent opening or closing of the gate by means of pre-blinking for 1.5 seconds.
- **Control unit gate opened output** (24V, 5W max): activated just after receiving the command of opening and disabled when the gate is completely closed.
- **Output Magnetic encoder supply**: this has to be used **only** on the **BZ1x00** boards for HERMES e ZEFIRO350 a 24V to supply their respective magnetic encoders. **One must rigorously respect the polarities of the supplies**
- **Encoder inputs**: they form the inputs for the signals coming from the Encoder placed on the 2 motors, enabling the measurement of the length traveled by the two leafs of the gate without the need of a limit-switch.
- **Pedestrian input**: enables the controlling of the opening and closing of only one (connected with M1 motor) shutter of the gate.
- **Open/Close input**: enables the sending of closing and opening commands of the gate according to the sequence that depends on the position of the dip switch SW-3.
- **Activated photocell in the closing mode input**: the activation of this input is disabled during the opening phase, stops and opens the gate during the closing and during the interval.
- **Activated photocell in the opening mode input**: the activation of this input causes, during the opening the gate, its immediate stop; if the photocell is deactivated, the gate starts the opening phase again.
- **Stop input**: if the Stop command is activated, all of the possible cycles and every starting command are disabled. The Stop command during the motion causes immediate stop of the gate and a slight inversion of the movement. If the Stop command is given during the interval, the work cycle is interrupted until the new command of closing.
- **2nd radio channel output (unpolarized contact)**: by the means of using the 2 channel receiver, it is possible to control an external supplementary unit.
- **Antenna input**: The connection of an external antenna have to be done with a coaxial cable (i.e. RG58)
- **Radio connector input (Molex connector)**: the unit is adapted to connect an accessory radio receiver card. The 1st card channel is connected parallel to the Open/Close input. The 2nd channel is connected in the terminals 24 – 25 (CH2)

FUNCTIONING MODES

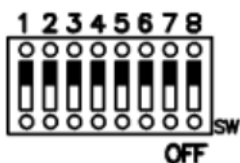

The unit may control various functions based on the combinations of the Dip Switches:

DIP	FUNCTION	ON	OFF
SW - 1	ELECTRONIC FRICTION M1	The motor M1 supplies the maximum thrust.	The motor M1 supplies the minimum thrust.
SW - 2	ELECTRONIC FRICTION M2	The motor M2 supplies the maximum thrust.	The motor M1 supplies the minimum thrust.
SW - 3	COMMAND OPEN/CLOSE	impulse opens – impulse blocks – impulse closes	impulse opens – impulse closes
SW - 4	AUTOMATIC CLOSING	The automatic operation is activated	The semi-automatic operation is activated
SW - 5	BATTERING RAM	The M1 shutter is closed for a second to free the electric lock and then the opening restarts.	The opening phase is not provided for the use of the battering ram.
SW - 6	SHUTTER DELAY	During the closing operation, the M1 shutter is activated after 3 seconds of the activation of the M2 shutter.	During the closing operation, the M1 shutter is activated after 7 seconds of the activation of the M2 shutter.
SW - 7	FUNCTIONING ½ MOTORS	Activated two – motors operation mode.	Activated one– motor operation mode.
SW - 8	AUTOMATIC LEARNING	Proceeds the operation of automatic learning of the shutter movements and bringing to automation the closing time.	The automatic learning phase is deactivated.

PROGRAMMING

- Manual opening of the gate (both shutters).
- Program SW - 8 = ON, the blinking unit will emit a steady light to inform the user that the programming procedure has been started.
- Press the Open/Close button or the radio control button once; the M2 shutter will close completely, followed, after 2 seconds, by the other one(M1). If the shutters are activated in the opening phase, power supply should be cut off and invert the connections in the motors in order to enable proper programming. (both shutters have to start closing)
- After closing the two shutters, starts the opening phase(automatically), first activating the M1 shutter and then the M2 one until reaching the mechanical positive stops in the opening phase (the process of reaching the end points proceeds in slow motion).
- From the moment when the shutters have reached the mechanical stops in the opening phase, the counting of automatic closing time starts; when the requested time has passed, one should press once again the Open/ Close button or the radio control button, in order to control the closing of the gate.
- When the closing operation has come to an end, program SW - 8 = OFF;

- The programming has finished, now set the functioning mode that you wish.

NOTE

1. **In order to secure always the safety of the automation and to enable the proper carrying out of the programming operation, it is necessary to use the mechanical positive stops at the end of the gate's course (in opening and in closing).**
2. The electric friction can be adjusted to make the two motors more or less sensitive to obstruction; if an obstruction is detected, in the opening or in the closing phase, the central unit, at first, reverses the course of the gate. If the obstruction is detected again, the central unit blocks the operation of the gate deactivating, if programmed, the process of automatic closing; it is necessary to give a new command. If the obstruction is detected for the third time, the central unit starts the emergency mode by opening the gate completely to the mechanical positive stops in the opening and then the gate closes automatically(if the automatic closing is programmed).
3. During the opening phase, with SW – 3 = OFF and with SW – 4 = ON, every Open/Close command(terminal 19) will be inactive, whereas during the closing phase the two-leaf movement is inverted with each impulse (CONDOMINIUM MODE). If the semi-automatic functioning is activated, with SW – 3 = OFF, every Open/Close command will cause the inversion of gate leaf movement, both during the opening and closing phase.
4. In the two-motor mode, the Open/Close command controls the activation of both gate leaves, whereas the pedestrian commands only the M1 gate leaf. Next, in the one – motor mode the Open/Close command causes the full activation of M1 gate leaf and the Pedestrian command is partly active.
5. The Open/Close command, after the power supply is cut or reset(by touching the two Pins marked as RST with the screwdriver point), provokes first the complete opening of the gate, and then the automatic closing up to the proper mechanical positive stops.
6. During the regular mode, the central unit blocks the gate leaves a few centimeters before the end point in the opening, in order to avoid striking the mechanical stops.
7. In the opening phase, the delay between the two gate leaves is 1,5 seconds

RECEIVER (OPTIONAL)

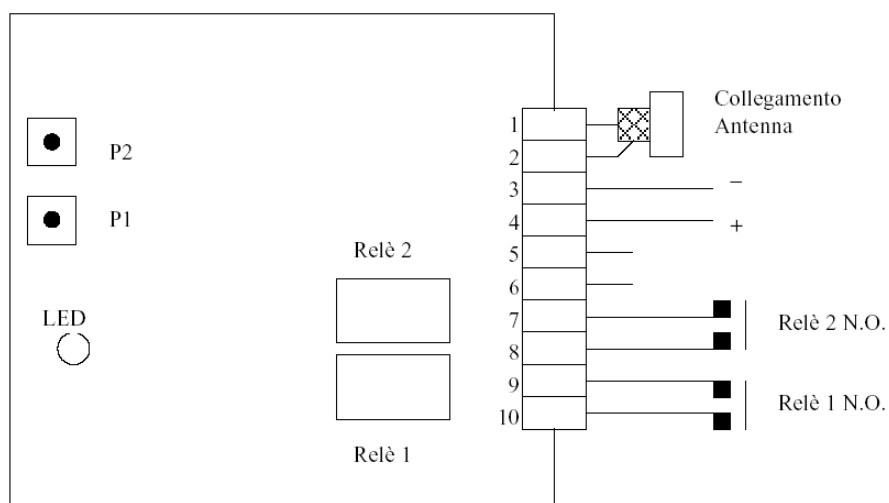

The receiver connected with the central unit is of the 2 channels type with the 1st channel connected parallel to the Open/Close input, while the 2nd is brought to the output of terminals 24 and 25 (contact N.O. unpolarized); the receiver can store up to 127 different codes in the requested channel. The memory content is saved also when the power supply is cut off.

PROGRAMMING THE RECEIVER

1) Pressing the button P1 for to choose the functioning mode

- a) Pressing P1 1 time inserts a code that activates the relay 1 in its monostable version.
- b) Pressing P1 2 times inserts a code that activates the relay 2 in its monostable version.
- c) Pressing P1 3 times inserts a code that activates the relay 1 in its bistable version.
- d) Pressing P1 4 times inserts a code that activates the relay 2 in its bistable version.

Attention :

- Wait at least 1 second before pressing the P1 button once again.
- After having carried out one of the 4 operations(a,b,c,d) wait until the LED switches on.

2) Recording /storing the code

The second phase consists of sending the code to be stored(for at least 1 second) by the transmitter; when the button is released, the LED situated on the receiver switches off, signaling that the code has been recognized and stored. If the code is not accepted the LED is on for approximately 10 seconds and after that time switches off automatically(the end of the operation).

ERASING THE CODE FROM THE MEMORY

- a) Press the P2 button situated on the receiver for at least 1 second; when released the LED switches off.
- b) Send the code to be erased for at least 1 second. When the LED switches off it means that the code has been cancelled.

ERASING ALL CODES FROM THE MEMORY

In order to erase all stored codes from the memory, press the P2 button for about 10 seconds until the LED goes out.

Rev. 0 - 03/06

Stagnoli s.r.l.

Via Mantova, Traversa 1^a, 105 A/B-25017 Lonato (Bs) - Italia

Tel. +39 030 9139511 Fax. +39 030 91380

www.stagnoli.com